

Specifications

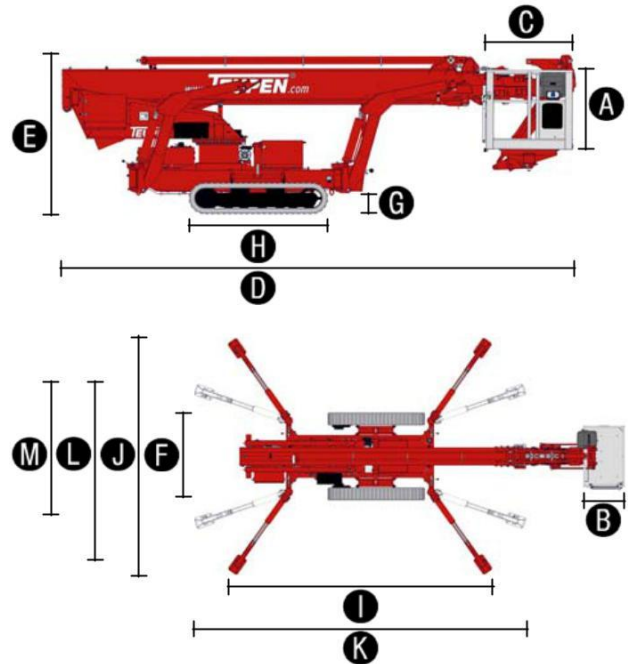

MEASUREMENTS	Metric	US
Working height, max.	30,00 m	97 ft 10 in
Horizontal outreach with 80 kg	15,70 m	51 ft 6 in
Horizontal outreach with 200 kg	14,00 m	45 ft 11 in
Platform height (A)	1,10 m	3 ft 7 in
Platform length (B)	0,80 m	2 ft 8 in
Platform width (C)	1,20 m	3 ft 11 in
Length, overall (D)	7,20 m	23 ft 8 in
Height, travelling position (E)	1,98 m	6 ft 6 in
Width, min. (F)	1,58 m	5 ft 3 in
Ground clearance, max. (G)	0,27 m	11 in
Track (L x W) (H)	1,92 m x 0,25 m	6 ft 2 in x 10 in
Length outrigger footprint standard (I)	5,30 m	17 ft 5 in
Width outrigger footprint standard (J)	4,75 m	15 ft 7 in
Length footprint one side narrow (K)	6,64 m	21 ft 9 in
Width footprint one side narrow (L)	3,95 m	12 ft 11 in
Width footprint both sides narrow (M)	2,99 m	9 ft 10 in
Outrigger plate (L x W)	0,31 m x 0,22 m	12 in x 8½ in



PRODUCTIVITY	Metric	US
Basket capacity	200 kg	441 lbs
Movable jib	180°	180°
Basket rotation	180°	180°
Turret rotation	450°	450°
To be jacked up on ground slope of	16,7°/30,0 %	16.7°/30.0 %
Height and width track adjustment	22/17 cm	8¾/6¾ in
Gradeability, max.	16,7°/30,0 %	16.7°/30.0 %
Slope angle	16,7°/30,0 %	16.7°/30.0 %
Travel speed	3,0 km/h	1.9 mph

WORKING ENVELOPE

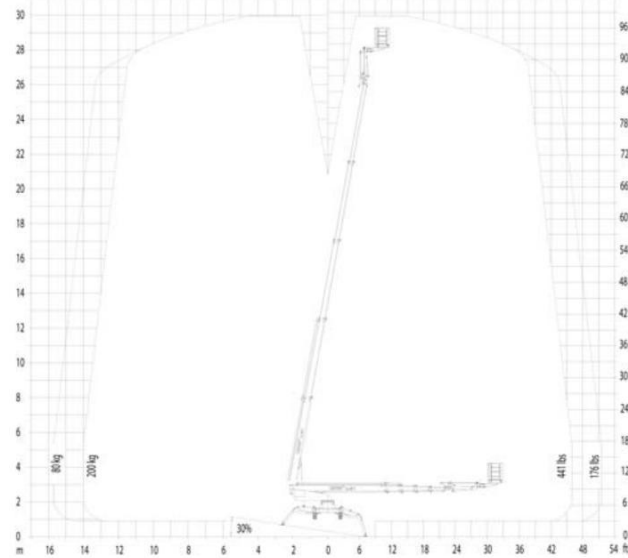

WEIGHT	Metric	US
Total weight	4300 kg	9480 lbs
Live load in travelling position	3,7 kN/m²	75.0 psf
Live load in working position	2,0 kN/m²	41.8 psf
Point load per outrigger plate, max.	26,0 kN	5845 lbf

STANDARDS COMPLIANCE



POWER	
Standard power sources (Electric and combustion engine)	1) Electric: EU: 230 V, 12,9 A, 2,2 kW US: 115 V, 19,3 A, 1,6 kW 2) Diesel: Kubota D 902-E3 (16,1 kW/21,6 hp)
Optional power source	Battery: 80 V
Fuel tank capacity Diesel engine	40,0 l 10.06 gal

Product specifications are subject to change without notice or obligation. Photographs and drawings in this document are for illustrative purposes only. Refer to the appropriate Operator's Manual for instructions on the proper use of this equipment. Failure to follow the appropriate Operator's Manual when using our equipment or to otherwise act irresponsibly may result in serious injury or death. The only warranty applicable to our equipment is the standard written warranty applicable to the particular product and sale and we make no other warranty, expressed or implied. Products and services listed may be trademarks, service marks or trade-names of Teupen Maschinenbau GmbH and/or its subsidiaries in the U.S.A. and many other countries. "Teupen", "Access redefined" and "LEO Series" are registered Trademarks of Teupen GmbH in the United States of America and many other countries. Version 2014-A © 2014 Teupen Maschinenbau GmbH.

Features

TRACK CHASSIS

- Powerful track drive with hydraulic braking system
- Precise maneuvering over sensitive electrohydraulic cable remote control
- Rubber tracks with specially arranged profile providing optimum grip
- White, non-marking rubber tracks
- Hydraulically height- and width adjustable track chassis

STABILISATION

- Fully-hydraulic, automatic levelling system with outrigger/stabiliser setup monitoring
- Variable stabiliser/outrigger system with one-side or both-sides narrow setup option

BOOM SYSTEM

- Telescoping boom made from robust steel and aluminium profiles on wear-resistant rollers
- All functions are available from one radio remote control panel
- Electric-proportional controls with intuitive operator guidance
- Robust, lockable control panel with integrated operation and display function
- Self-levelling platform with fully-hydraulic levelling system
- 180° basket rotation
- Boom rotation via high-performance slew ring, worm gear and hydraulic motor
- Basket changing system
- 180° movable jib, even in load limit range
- Coming Home Function - automatic return of boom into transport position

POWER SOURCES

- 230 V electric motor (EU), 115 V electric motor (US)
- Kubota Diesel engine D902-E3 (16,1 kW/21,6 hp), silenced
- Start-Stop switch of combustion engine in the basket

PRODUCTIVITY, SAFETY, QUALITY

- 230 V (EU), 115 V (US) power outlet in the basket
- Ergonomically shaped basket with eyelets for safety belts and tool tray
- Lockable storage box for radio remote control
- High-quality paint in RAL 3020 (red)
- Hydraulic emergency lowering via hand pump
- Cables and hoses are safely routed through the boom structure
- Biodegradable hydraulic oil
- Lock valves - hydraulic return valves directly on all hydraulic cylinders
- Relief valves protecting the hydraulic system from too high pressures
- Protective covers for oil-tank, emergency controls and connecting cables and hoses
- Easily removable covers for optimal accessibility
- Hour meter
- Fuzzy IV controls with interactive display



OPTIONS

- Electric emergency lowering (12 kg/24 lbs additional weight)
This option can not be combined with the battery drive
- Custom paintwork, one colour, according to RAL scheme (except metallic coatings, signal- or special colors)
- Custom paintwork, two colours, according to RAL scheme (except metallic coatings, signal- or special colors)
- 80 V battery drive with charger instead of Kubota Diesel engine (extra weight approx 400 kg/882 lbs). This option can not be combined with the electric emergency lowering.
- Additional electric drive 230 V/50 Hz (115 V US) for an optimal adjustment of the electric pump to various operation modes
- Height shut-off system for boom, 2 set-points
- Separating grate in basket (10 kg/22 lbs additional weight)
- Basket* (900 x 800 mm/2 ft 11 in x 2 ft 7 in) instead of the standard basket. This option can only be ordered in combination with the basket holder.
- Basket holder, detachable (for 900 x 800 mm/2 ft 11 in x 2 ft 7 in) basket

**Choosing other basket sizes results in different machine specifications and performance.*

ACCESSORIES

- Outrigger/Stabiliser pad (340 x 850 mm/1 ft 1 in x 2 ft 9 in)
- Track mat (2000 x 800 x 15 mm/6 ft 6 in x 3 ft 3 in x ½ in) fits exactly into transport frame
- Safety harness
- 2 protective track covers, made of high-quality polypropylene fabric
- Treecare package, consisting of:
 - Protective cover hydraulic tank
 - Protective cover ground control panel
 - Covers on piston rod (outrigger/stabiliser) cylinders
- 4 covers on piston rod (outrigger/stabiliser) cylinders (additional weight: 10 kg/22 lbs)

TRANSPORT FRAMES

- Subframe for truck Mitsubishi Canter (Total weight 450 kg/992 lbs)

